

Dynamic Modeling and Simulation of an Optimized Proton Exchange Membrane Fuel Cell System

M. T. Outeiro⁽¹⁾, R. Chibante⁽²⁾, A. S. Carvalho⁽³⁾, A. T. de Almeida⁽⁴⁾,

- ⁽¹⁾ Instituto Superior de Engenharia de Coimbra, R. Pedro Nunes, Quinta da Nora, 3030 Coimbra, Telef: 239 790 200, Fax: 239 790 201, Email: touteiro@mail.isec.pt
- ⁽²⁾ Instituto Superior de Engenharia do Porto, R. Dr. António Bernardino de Almeida, 431 4200-072 Porto, Telef: 22 8340500, Fax: 2 8321159, Email: rmc@isep.ipp.pt
- ⁽³⁾ Faculdade de Engenharia da Universidade do Porto, ISR-DEEC, Rua Roberto Frias s/n 4200-465 Porto, Telef: 22 508 18 18, Fax: 22 508 14 43, Email: asc@fe.up.pt
- ⁽⁴⁾ Faculdade de Ciências e Tecnologia da Universidade de Coimbra, ISR-DEEC, Pólo II, 3030 Coimbra, Telef: 239 796 218, Fax: 239 406 672, Email: adealmeida@isr.uc.pt

Abstract

This paper presents a dynamic PEM fuel cell system model, which is implemented in Matlab/Simulink. The main difficulty in obtaining an accurate PEM fuel cell dynamical model is the lack of manufacturer information about the exact values of the parameters that should be used in the model.

In order to estimate the PEM fuel cell model parameters, an optimization based approach is used. The optimization is carried out using the Simulated Annealing (SA). This optimization process evolves, converging to a minimum of the objective function. The major advantage of SA algorithm is its ability to avoid becoming trapped in local minimum. The algorithm employs a random search which not only accepts changes that decrease the objective function, but also some changes that increase it. The latter can be accepted with a probability. Its flexibility and robustness as a global search method are also extremely important advantages of this method.

A good agreement between experimental and simulated results is observed. This provides useful information about model parameters, which enables the design of the fuel cell systems through simulation.

Keywords: PEM fuel cell, modelling and simulation, system optimization, simulated annealing.

1. Introduction

Have you ever heard of the phrase “sustainable development?” Sustainable development means to meet the needs of the present without compromising the ability of future generations to meet their own needs [1]. With energy use rising every year, oil production growing at alarming rates and greenhouse gas emissions on the rise, unfortunately the world is a lot closer to the category of “unsustainable development.”

Although fossil fuel reserves are still large, they are finite and the world’s crude oil production is projected to peak sometime in the early 21st century [1].

With the technology advances, the opportunity to move closer to the sustainable path becomes much easier. Renewable energy sources have been around for quite some time, but for numerous reasons they have not yet emerged as primary power sources.

The introduction of fuel cell systems into the power generation market will not only supply clean renewable energy to millions of users, but it will help reduce the dependence on oil, which is of critical importance, for the industrialized countries. In addition, fuel cells are ideal for distributed power generation applications. They could be used as electric generating power plants, or as a nearly exhaust-free power source for automobiles. They are already generating power for hospitals, hotels, airports, universities and military installations around the world, and can easily be adapted for supplying power to homes, cars and anything else that uses electricity. Fuel cells produce little or no emissions and are more efficient than combustion generators. They have virtually no moving parts, are highly dependable and produce high-quality power that is ideally suited to run sensitive equipment. Fuel cells are extremely efficient and produce electricity more economically than the existing electric utility grid and other power generation technologies.

2.1 Fuel cell types

There are several different types of fuel cells, most often categorized by the type of electrolyte present. Four of the more common fuel cells are proton exchange membrane fuel cells (PEMFC), phosphoric acid fuel cells (PAFC), molten carbonate fuel cells (MCFC), and solid oxide fuel cells (SOFC). The PEMFC is probably the most well known fuel cell and shows promise for applications in the medium power range. Because of its efficiency and relatively low operating temperature range, the PEMFC is ideal for residential applications and is the chosen fuel cell for the system under study.

2.2 Fuel cell operation

Fuel cells are electrochemical devices that convert chemical energy, typically from hydrogen, directly into electrical energy. Similar to a battery, a fuel cell consists of two electrodes (anode and cathode) and an electrolyte. A basic scheme of a single cell is shown in Figure 1.

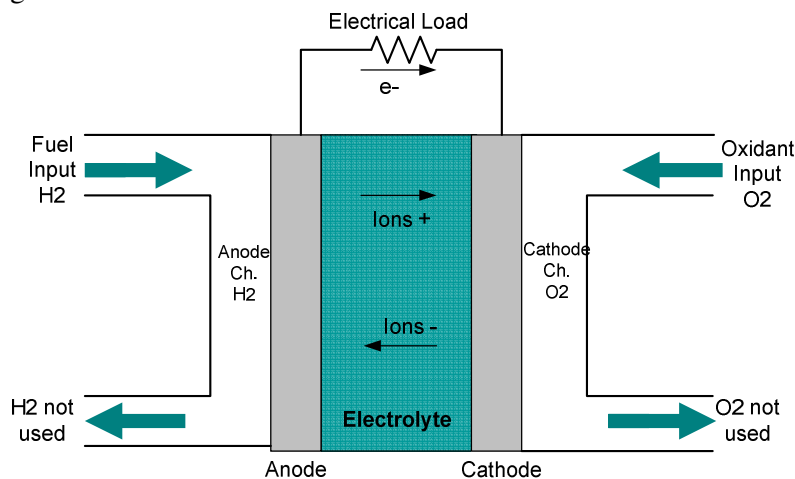

Fig.1 – Scheme of a single cell.

The process in the anode side is as follows: Diatomic hydrogen is circulated through the anode channel in the separation plates and, therefore, distributed across the PEM and catalysts by the microporous Gas Diffusion Layer. When the hydrogen gets near activation sites in the catalyst and transfer sites on the PEM, the molecules break up to

single atoms and the hydrogen nuclei attach to the PEM. The electrons (e-) left behind attach to the conductive plate and are directed to an external circuit to produce power. As the Fuel Cell produces power, some of the water from the cathode side permeates to the anode side increasing the efficiency of the proton transfer to the PEM.

The process in the cathode side is as follows: Heated, humidified air containing diatomic oxygen is distributed across the PEM and catalysts through the channels in the separation plates and microporous Gas Diffusion Layer. When the oxygen gets near activation sites in the catalyst, the molecules break up to single atoms. Electrons return from the external circuit and the cathode separation plate and the hydrogen protons (H+) are pulled from the PEM. Two electrons, two protons and an oxygen atom form a water molecule with release of excess heat.

3. Dynamical model of the PEM fuel cell

An electrical equivalent circuit can be used to model the fuel cell dynamical behaviour [2], [4], as represented in Figure 2. Equations (1) and (2) represent the fuel cell static electrochemical behaviour.

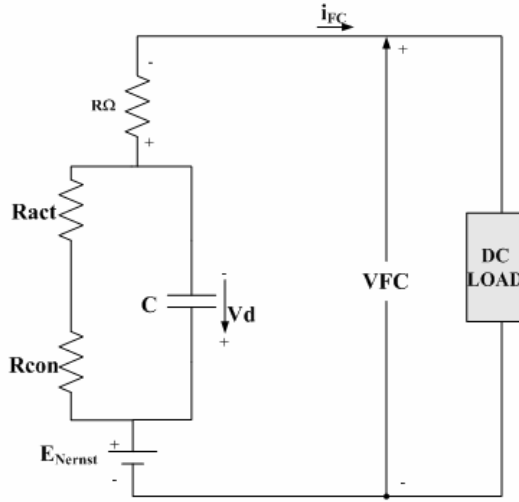

Fig.2 – Electrical equivalent circuit of fuel cell dynamical model.

The output voltage of a single cell can be defined as the result of the following expression [10]:

$$V_{FC} = E_{Nernst} - V_{act} - V_{Ohmic} - V_{con} \quad (1)$$

For n cells connected in series, forming a stack, the voltage, Vs can be calculated by:

$$V_s = n \times V_{FC} \quad (2)$$

In the equation (1), E_{Nernst} is the thermodynamic potential of the cell and it represents its reversible voltage; V_{act} is the voltage drop due to the activation of the anode and cathode (also known as activation over potential), V_{ohmic} is the ohmic voltage drop (also known as ohmic overpotential), a measure of the ohmic voltage drop resulting from the resistances of the conduction of protons through the solid electrolyte and the electrons through its path; and V_{con} represents the voltage drop resulting from the reduction in concentration of the reactants gases or, alternatively, from the transport of mass of

oxygen and hydrogen (also known as concentration over potential). But, there is another voltage drop associated to the internal currents and the fuel crossover [4]. This voltage drop is considered in the model, using a fixed current density even at no-load operation (represented by J_n). The first term of (1) represents the fuel cell open circuit voltage, and the three last terms represent reductions in this voltage to supply the useful voltage across the cell electrodes, V_{FC} , for a certain operation current.

3.1 Dynamics of the cell

Taking in account the phenomenon known as "charge double layer", on which the interface electrode/electrolyte acts as storage of electrical charges and energy, represented by an electrical capacitor in the electrical equivalent circuit of figure 2, the dynamical equation of the model is represented by:

$$\frac{dV_d}{dt} = \left(\frac{1}{C} \times i_{FC} \right) - \left(\frac{1}{\tau} \times V_d \right) \quad (3)$$

where V_d represents the dynamical voltage across the equivalent capacitor (associated with V_{act} and V_{con}); C is the equivalent electrical capacitance; and, τ is the fuel cell electrical time constant defined as:

$$\tau = C \times Ra = C \times (R_{act} + R_{con}) = C \times \left(\frac{V_{act} + V_{con}}{i_{FC}} \right) \quad (4)$$

where, Ra is an equivalent resistance.

Including the dynamic behaviour represented by (11), the resulting fuel cell voltage is then defined by:

$$V_{FC} = E_{Nernst} - V_{Ohmic} - V_d \quad (5)$$

3.2 Power generation and efficiency

The electrical output of the cell can be linked to any load, with no restriction related to the load type, since the power supplied by the stack is enough to feed it.

The load can be represented through a boost DC/DC converter, followed by a dc/ac converter and linked to the grid through a transformer, if the system is used to inject energy into the grid. The load can be purely resistive or a resistive-inductive if the system is used in isolated form. In any case, the density of current of the cell A/cm is defined by the expression:

$$J = \frac{i_{FC}}{A} \quad (6)$$

And the instantaneous electrical power supplied by the cell to the load can be determined by the equation:

$$P_{FC} = i_{FC} \times V_{FC} \quad (7)$$

where V_{FC} is the cell output voltage for each operating condition, and P_{FC} is the output power, in watts. Finally, the FC efficiency can be determined by the equation:

$$\eta = \mu_f \times \frac{V_{FC}}{1,48} \quad (8)$$

where μ_f is the fuel utilization coefficient, in the range of 95%, and 1.48 V represents the maximum voltage that can be obtained. Fuel utilization is assumed to be constant, which is valid where the fuel cell has a hydrogen flow rate control.

4. System optimization

The dynamical model of the PEM fuel cell system presented in previous section requires the definition of several parameters: A- cell active area (cm²), l- membrane thickness (μm), RC- contact resistance (Ω), ξ_i (i=1,2,3,4) and ψ - parametric coefficients, J_n- no-load current density (A/cm²), J_{max}- maximum current density (A/cm²) and C- equivalent to electrical capacitance (F). These parameters are estimated by an optimization process. To solve the optimization problem, the Simulated Annealing (SA) optimization algorithm was used.

Considering an initial set of parameters, the PEM fuel cell model compares simulated and experimental waveforms, producing an error value (objective function). Then, parameters are varied and simulation is re-executed to produce new waveforms. This is again compared with measured data and optimization continues accordingly. Once parameters have converged to give a minimum error, optimization process stops. It can be represented by the following scheme.

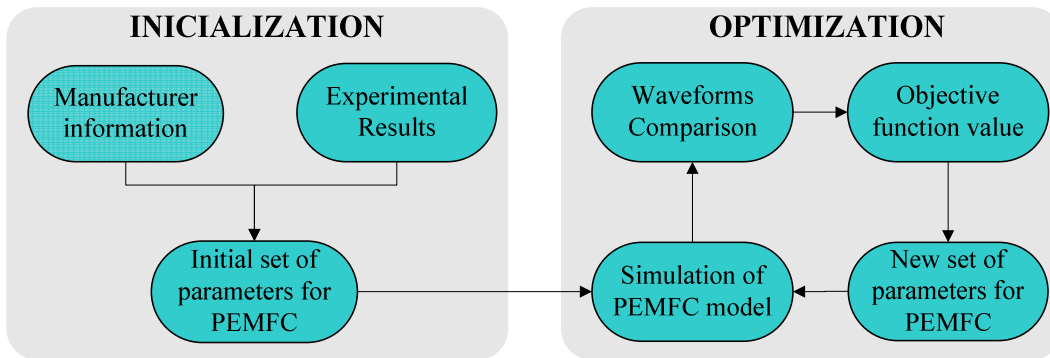

The SA algorithm is a random-search technique which exploits an analogy between the way in which a metal cools and freezes into a minimum energy crystalline structure (then annealing process) and the search for a minimum in a more general system.

A major advantage of SA is its ability to avoid becoming trapped in local minimum.

The algorithm employs a random search which not only accepts changes that decrease the objective function f , but also some changes that increase it. The latter can be accepted with a probability p . Its flexibility and robustness as a global search method are also extremely important advantages of this method.

Using the data provided by experimental tests, an optimal set of model parameters were obtained.

In figures 3 and 4 the simulated and experimental waveforms of stack voltage (V_{FC}) are compared. The figures clearly illustrate the efficiency of the optimization process.

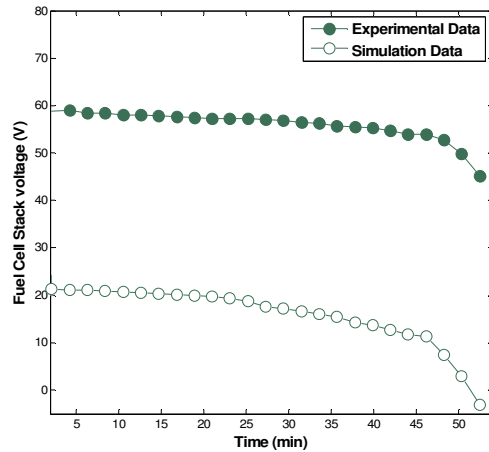

Fig.3 – Waveforms before SA optimization

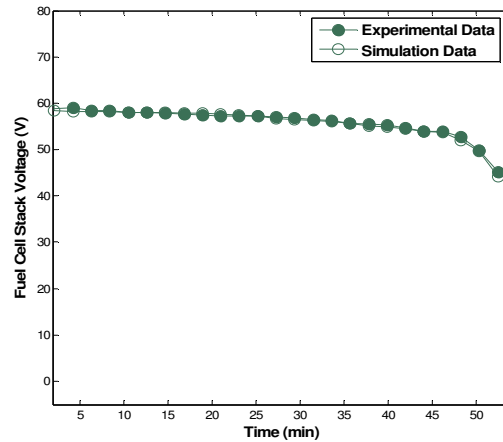

Fig.4 – Waveforms after SA optimization

5. Conclusions

Fuel cells technology is rapidly becoming economically competitive with conventional power generation technologies. They will continue to develop and mature over the next few years.

In this paper, the methodology adopted for the dynamic modelization of a PEM fuel cell system was presented, which was implemented in Matlab and Simulink software.

Fuel cell optimization is an interesting area of research. The models need to be adequate in order to obtain the correct results for the fuel cell systems operation. Most of the parameters used in the PEM fuel cells were taken in account to obtain their realistic dynamic model.

The method adopted in order to optimize the operation conditions of the PEM fuel cell system was SA algorithm. This method forces the convergence to a minimum of the objective function.

The optimization results show a good agreement between experimental and simulated waveforms and provide useful information for the PEM fuel cell system model.

References

- [1] S. Thomas and M. Zalowitz, "Fuel Cells-Green Power," Los Alamos National Laboratory (LA-UR-99-3231), 1999.
- [2] Corrêa, J.M., et al., Sensitivity Analysis of the Modeling Parameters Used in Simulation of Proton Exchange Membrane Fuel Cells. IEEE Transaction on Energy Conversion, 2005. 20(1): p. 204-210.
- [3] Corrêa, J.M., et al., Simulation of Fuel-Cell Stacks Using a Computer-Controlled Power Rectifier With the Purposes of Actual High-Power Injection Applications. IEEE Transaction on Industry Applications, 2003. 39(4): p. 1136-1142.
- [4] Corrêa, J.M., et al., An Electrochemical-Based Fuel Cell Model Suitable for Electrical Engineering Automation Approach. IEEE Transaction on Industrial Electronics, 2004. 51(5): p. 1103-1112.